

Flexile LG

MIDNIGHT

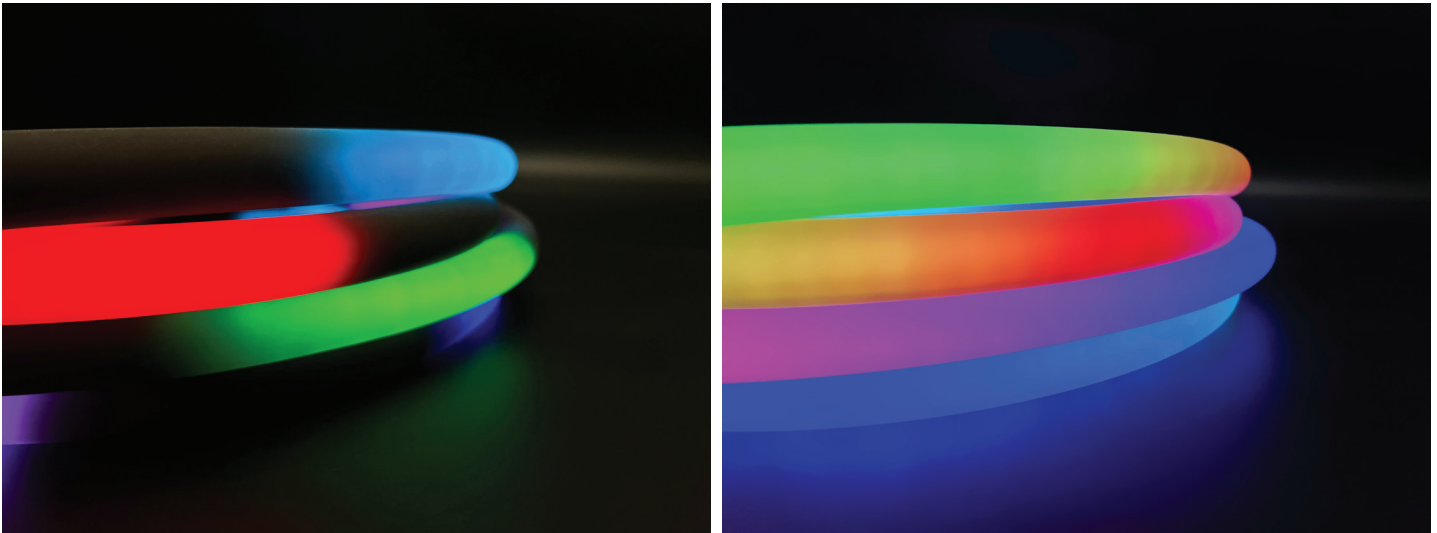



Project: _____ Type: _____

- Tivoli’s Flexile has a new look! Flexile Midnight - with an all black jacket that reveals color when lit
- Compare to traditional neon 360° lighted surface illuminates uniformly without any shadowing
- High luminous efficiency with LM80 report
- Easily bend to any shape with superior flexibility
- UV Stabilized with food-grade environmental silicone housing (no yellowing or cracking)
- Resistance to saline solutions, acids, alkali, and corrosive gases
- Low Voltage 12V DC



Dimensions

Front Power Lead

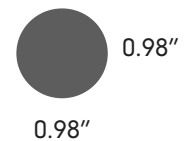

Side Power Lead

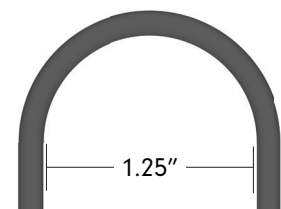

NOTE: Total run length including power lead and fixture must not exceed 19'

Order Guide

PRODUCT CODE	PROFILE	POWER LEAD DIRECTION	LED COLOR	LENGTH	VOLTAGE
FLXM	LG		RGB		12
FLXM = Flexile Midnight 360° Light	LG = Large	F = Front S = Side	RGB = RGB mixing	024 = 2' 048 = 4' 078 = 6' 6" 096 = 8'	12 = 12V DC

For custom cut lengths consult factory for lead time and MOQ

Extra Lead Prep

FLX-XEP

Extra lead wire for extended length.
Sold per ft.

Specification

LED Intensity	Red	Green	Blue	White (All On)
Lumens (lm/ft)	10	30.4	7.62	45.73
Beam Angle	360°			
Electrical				
Dimming/Control	SPI			
Input Voltage	12V DC			
IC	UCS1903			
Power Consumption (W/ft)	7.3			
Maximum Run Electrical	8'			
Maximum Run Data (1 Universe)	6' 6"			
Physical				
LED	3838			
Sleeve Color	Black			
Dimensions (DIA) Flexile	0.98"			
Cut Increments (factory cut only)	0.47"			
Bend Radius	1.25"			
Material (Flexile)	Flame, UV, Solvent, Saltwater Resistant Silicone			
Storage Temperature	-25°C / -13°F ~ +60°C / +140°F			
Working Temperature	-20°C / -4°F ~ 50°C / +122°F			
Certification and Testing				
Certification	UL, CE, RoHS			
Environment	Damp/Wet rated fixture only			
IP Rating	IP65 rated fixture only			
Rated Hours (TM80)	70000 hrs.			
Warranty	3 Years			

Data Operation & Wiring Diagram Artnet to SPI ON-LINE operation

MDRX-NBLA (Live)

This is a live control performance setup using the MDRX-NBLA-XX interface. Widely used for concerts or performance-based manipulation. Use of a live network is necessary for communication between MADRIX 5 software and Flexile Midnight.

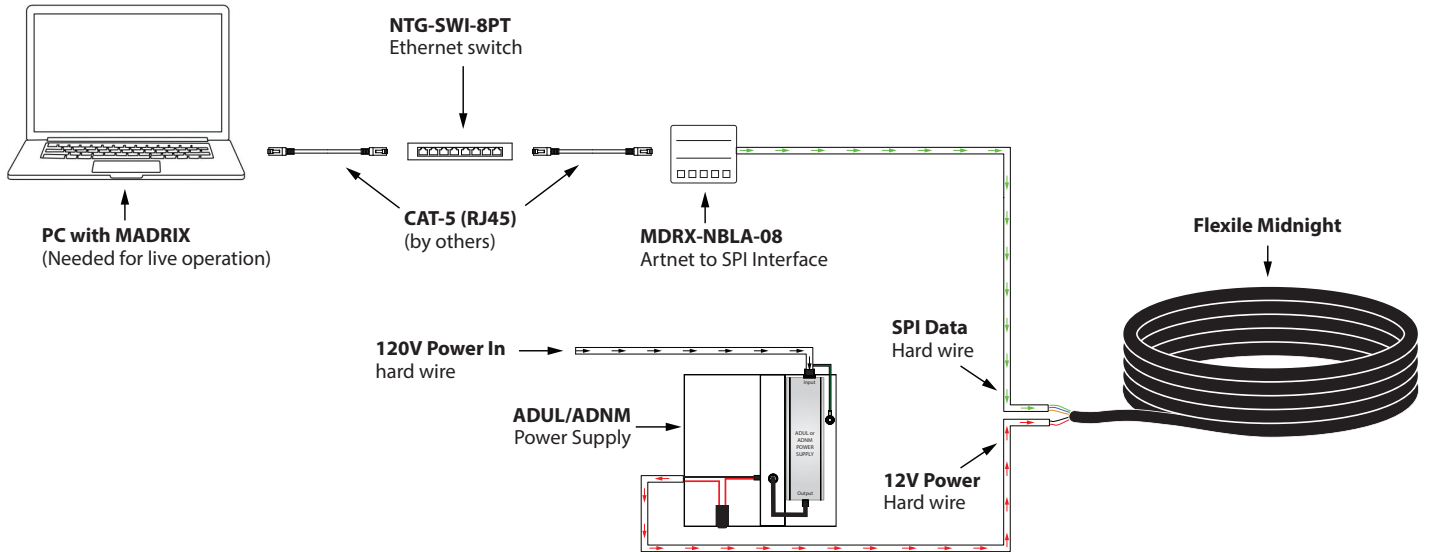

ARTNET-S (Live)

This is a live control performance setup using the ARTNET-S-X-SPI interface. Widely used for concerts or performance-based manipulation. Use of a live network is necessary for communication between MADRIX 5 software and Flexile Midnight.

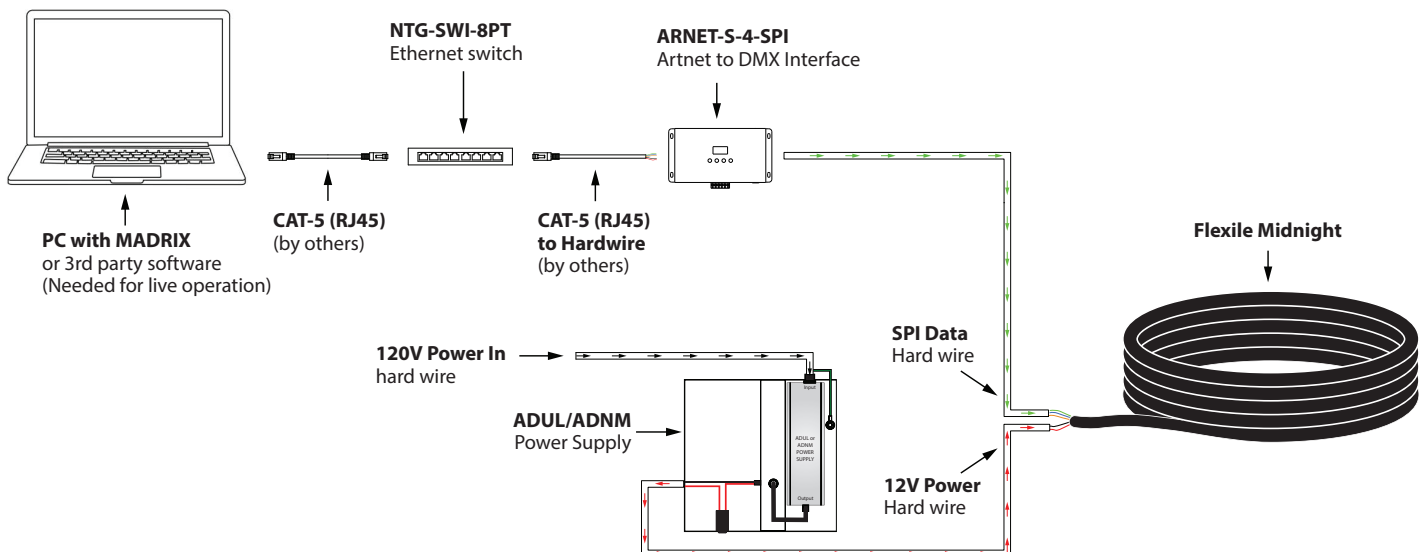

Data Operation & Wiring Diagram Artnet to SPI OFF-LINE operation

MDRX-AURA (Preset)

A stand-alone system with no need for support via network/software (MADRIX 5). Once scene playback is saved to AURA hardware via lighting software, PC/network can be removed from the system using only the AURA hardware to control playback. Please refer to the AURA specification for setup/record information.

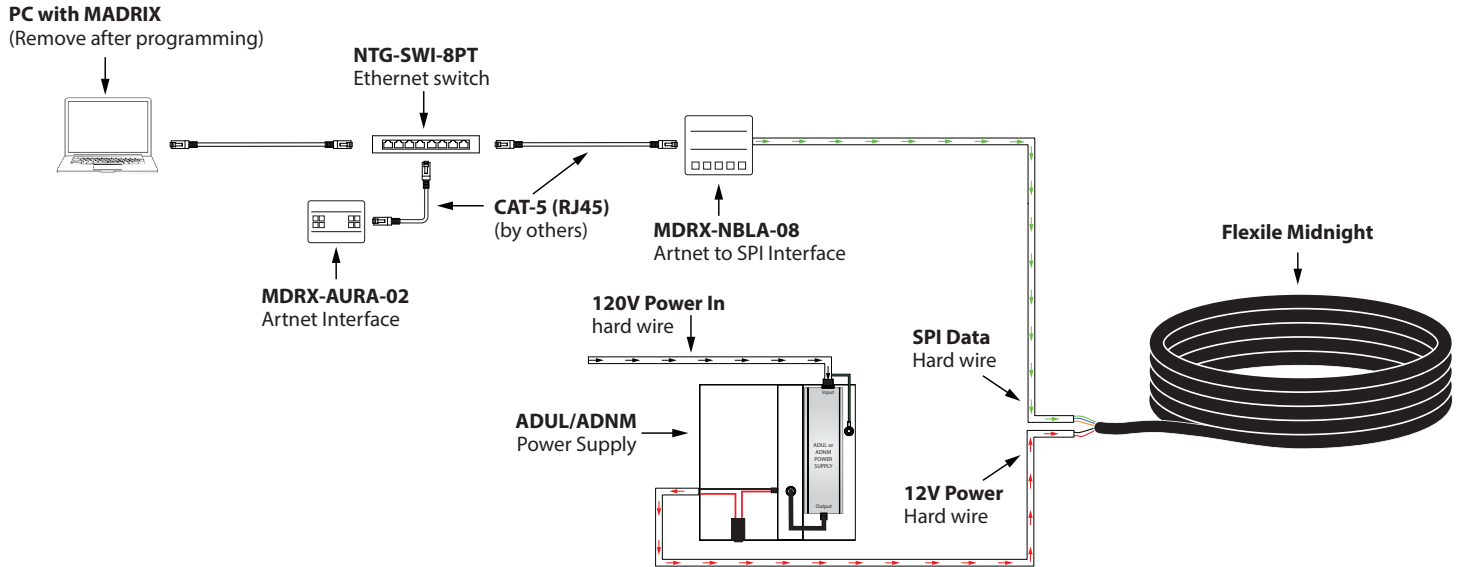

ARTNET-S (Preset)

A stand-alone system with no need for support via network/software (MADRIX 5). Once scene playback is saved to ARTNET-S hardware via lighting software, PC/network can be removed from the system using only the ARTNET-S hardware to control playback. Please refer to the ARTNET-S specification for setup/record information.

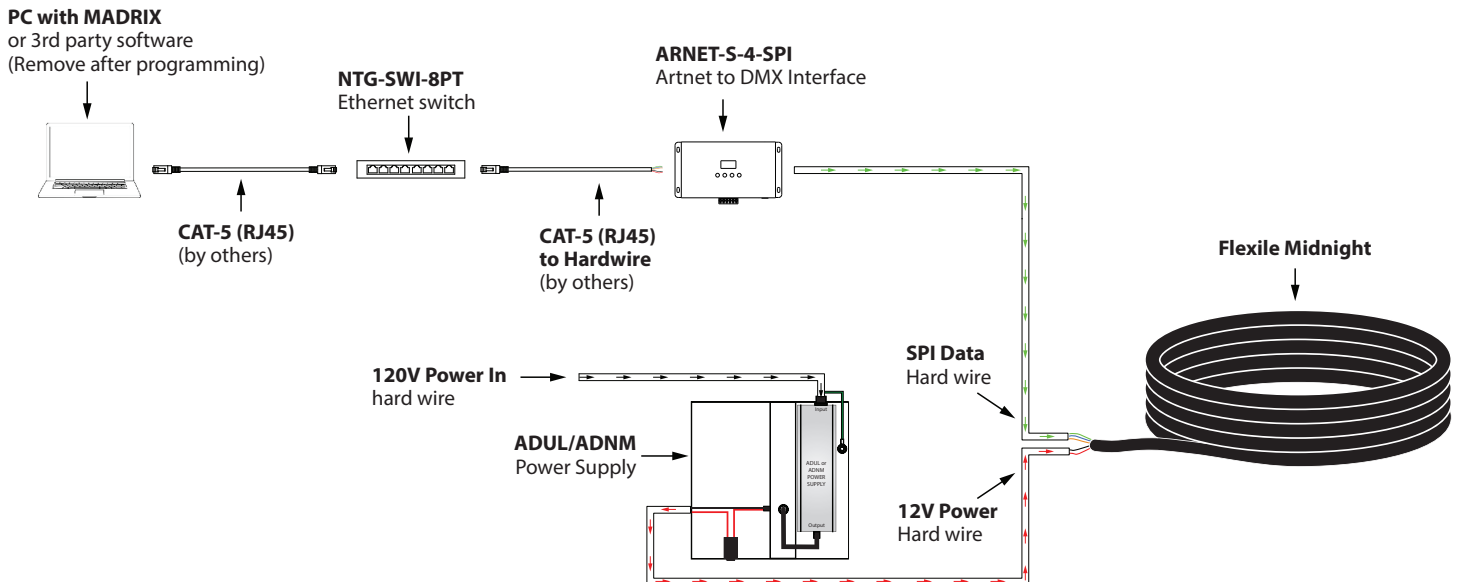

Data Operation & Wiring Diagram DMX to SPI ON-LINE operation

MDRX-LUNA or ARTNET-L (Live)

This is a live control performance setup using the MDRX-LUNA-XX or ARTNET-L-XX-512 interface. Widely used for concerts or performance-based manipulation. Use of a live network is necessary for communication between MADRIX 5 software and Flexile Midnight.

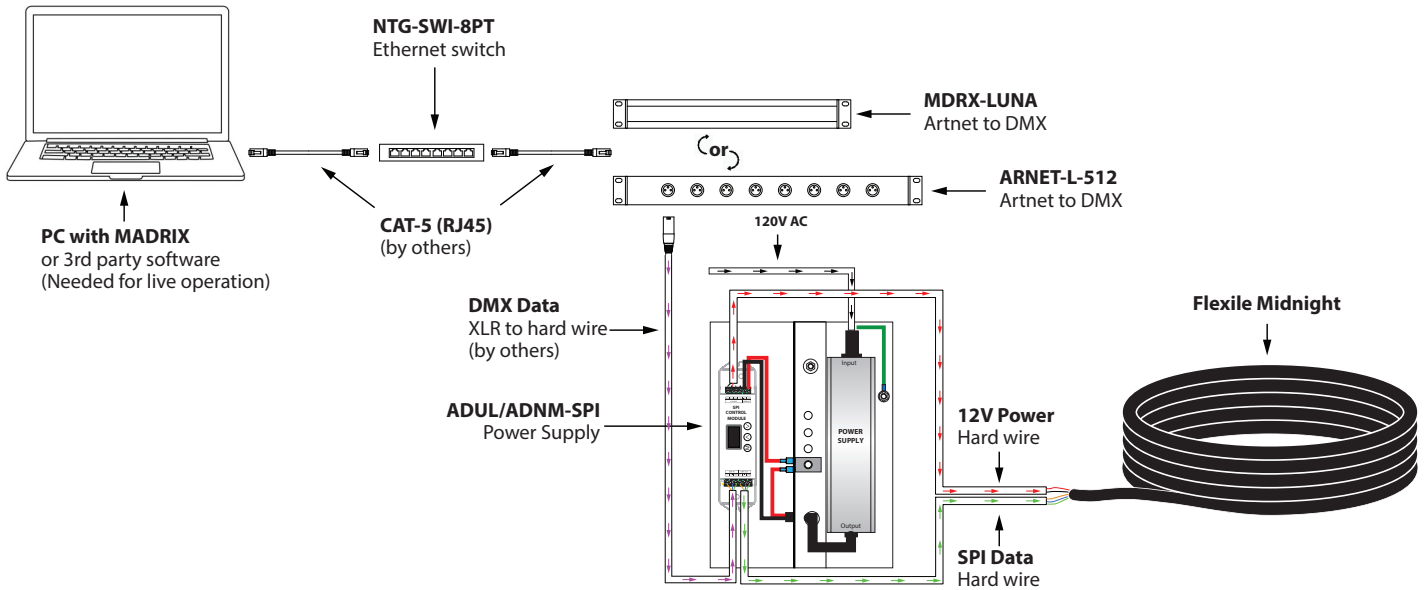

ARTNET-S (Live)

This is a live control performance setup using the ARTNET-S-X-512 interface. Widely used for concerts or performance-based manipulation. Use of a live network is necessary for communication between MADRIX 5 software and Flexile Midnight.

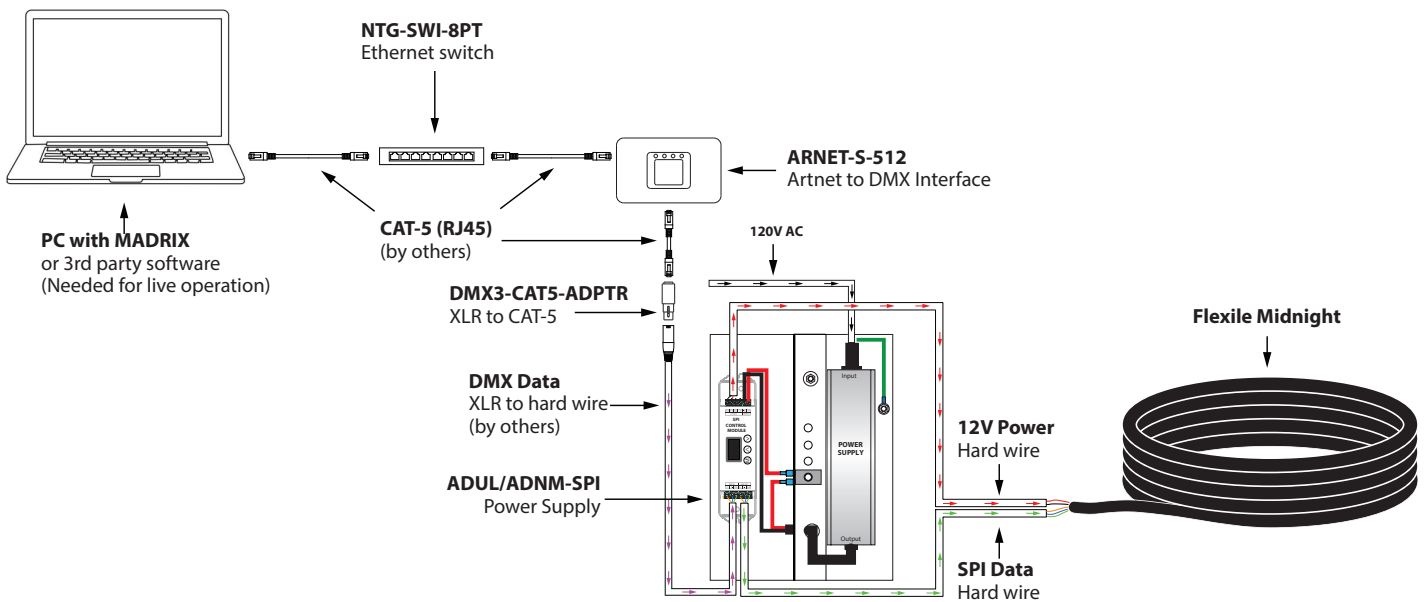

Data Operation & Wiring Diagram DMX to SPI OFF-LINE operation

MDRX-LUNA or ARTNET-L (Preset)

A stand-alone system with no need for support via network/software (MADRIX 5). Once scene playback is saved to AURA hardware via lighting software, PC/network can be removed from the system using only the AURA to control playback. Integrate with MDRX-LUNA or ARTNET-L for DMX system. Please refer to the AURA, MDRX-LUNA or ARTNET-L-512 specification for setup and record information.

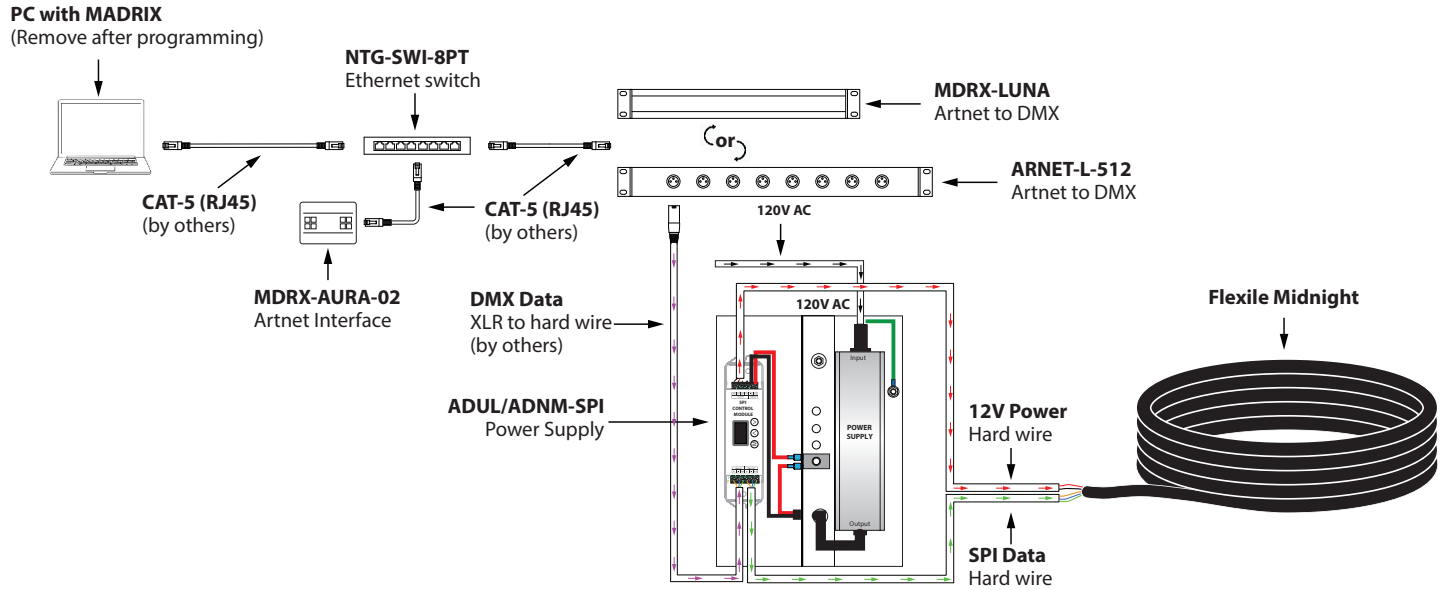

ARTNET-S (Preset)

A stand-alone system with no need for support via network/software (MADRIX 5). Once scene playback is saved to ARTNET-S-X512 hardware via lighting software, PC/network can be removed from the system using only the ARTNET-S-X512 to control playback. Please refer to the ARTNET-S-512 specification for setup and record information.

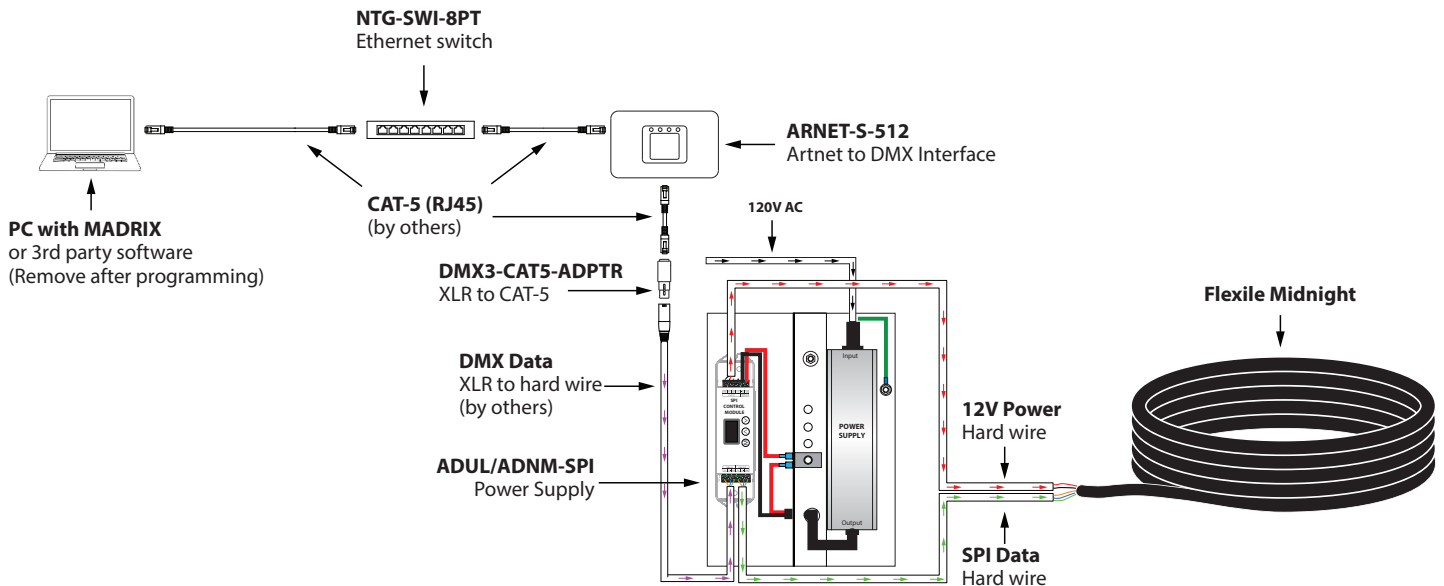

Controls



ARTNET-S-8-512
8 port universe Artnet to DMX interface, 4096 DMX channels Programmable for playback and live support (Online or Offline option)



MDRX-AURA-XX
X = 02, 08, 32 (ports)
MADRIX Luna 2, 8, 32 port universe Artnet to DMX interface. Programmable for playback and live support (Online or Offline option)



MDRX-NBLA-08
Up to 8 universes. SPI decoder receives control over ethernet network or USB delivering zero lag to your fixture



ARTNET-S-X-SPI
X = 4 (4 port), 8 (8 port)
Artnet to SPI interface. Programmable for playback and live support (Online or Offline option)

Network Hardware



MDRX-LUNA-XX
X = 04, 08, 16 (ports)
MADRIX Luna 4, 8, 16 port universe Artnet to DMX interface
16 port 8192, 8 port 4096, 4 port 2048 DMX channels



ARTNET-L-X-512
X = 8, 16 (ports)
8 or 16 port universe Artnet to DMX interface,
16 port 8192 DMX channels
8 port 4096 DMX channels



NTG-SWI-16PT
NETGEAR 16-Port gigabit gthernet Unmanaged Switch



NTG-SWI-8PT
NETGEAR 8-Port gigabit gthernet Unmanaged Switch



DMX3-CAT5-ADPTR
DMX adapter
3-pin XLR female to RJ45

Key & Software Levels



MADRIX KEY

A USB dongle unlocks the software’s full output. You can freely switch between different PCs as it is not bound to a specific one. It only needs to be activated online once.

MADRIX 5 LICENSE UPGRADES

You can easily upgrade your MADRIX 5 KEY to any higher license at any time, increasing the available output.

MADRIX 5 Key & Software Cat No	MDRX-LC-5S	MDRX-LC-5E	MDRX-LC-5B	MDRX-LC-5P	MDRX-LC-5U	MDRX-LC-5M
Level	START	ENTRY	BASIC	PROFESSIONAL	ULTIMATE	MAXIMUM
DMX-Based Output						
DMX Channels	1,024	4,096	16,384	65,536	262,144	1,048,576
DMX Universe Example	2	8	32	128	512	2,048
RGB Voxels Example	341	1,365	5,461	21,845	87,381	349,525
DVI-Based Output						
DVI Voxels	4,096	16,384	262,144	1,048,576	2,097,152	2,097,152
Render Resolution Example	64 X 64 PIXELS	128 X 128 PIXELS	512 X 512 PIXELS	1,024 X 1,024 PIXELS	2,048 X 1,024 PIXELS	2,048 X 1,024 PIXELS

Mounting Options

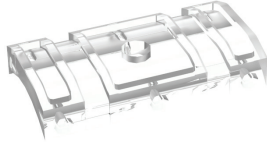

FLX-LG-MTBK-LP

Clear, low-profile polycarbonate bracket for surface mount application
Includes: (2) brackets, (14) nails, and (5) zip ties

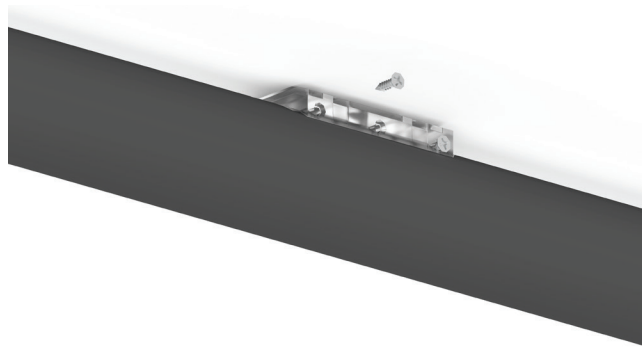

FLX-LG-MTBK-SEMICIRCLE-BK

Black Metal Flush Mounting Bracket
Natural aluminum finish
Includes: (2) bracket sets, (2) set screws and hardware

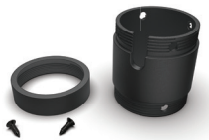

FLX-LG-JOINR-CIR-BK

Black Metal Joiner bracket
Can be coupled with telescoping arm for an circular overhead application
Includes: (1) bracket and hardware



FLX-LG-TEL-MTBK-1-BK

Black telescoping bracket with clear tube clip. Bracket extends to maximum length of 24" and a minimum of 13". Achievable Flexile bend radius of 15" with a recommended on-center spacing of 15" of each bracket. Includes: (1) extension bracket and hardware

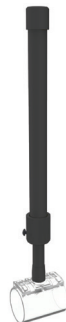

FLX-LG-SUS-MTBK-1

72" suspension cable with mounting hardware. Includes a 1.5" clear polycarbonate tube for uninterrupted 360 light distribution.



Mounting Options

FLX-LG-H-X-PNDT

X = 4 (46"), 8 (96")
 Horizontal clear polycarbonate tube includes two 72" cables and hardware for 4', and four 72" cables and hardware for 8'

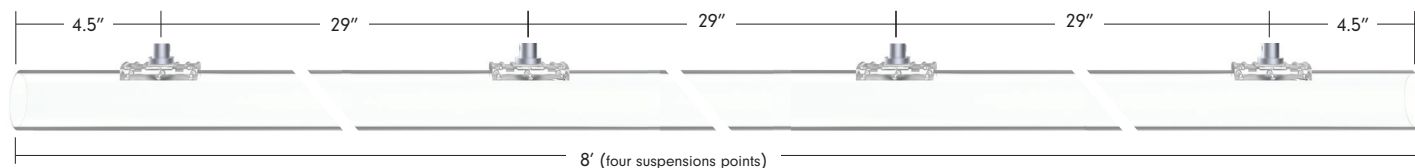
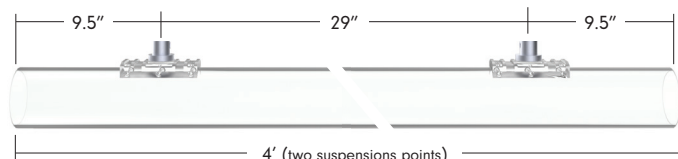
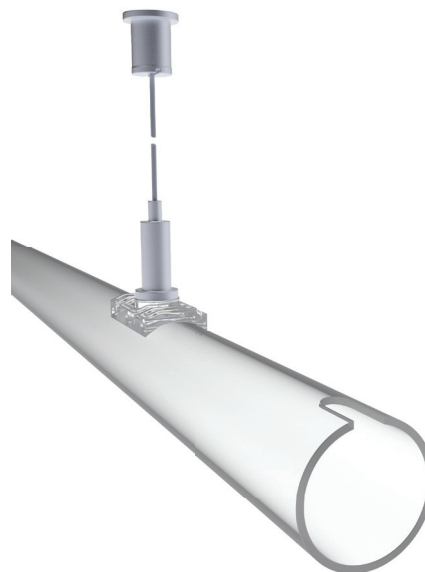

FLX-LG-CL-CLIP
 PC clip closed 1
 Mount spacing 15"
 Bend diameter 2.5"
 sold each



FLX-LG-CL-CHAN
 PC channel closed 6.5
 Bend diameter 2.5"
 sold each



FLX-LG-OP-CLIP
 PC clip open 2.36"
 Mounting spacing 15"
 Bend diameter 3"
 *sold each



FLX-LG-OP-CHAN
 PC channel open 6.5'
 Bend diameter 3"
 *sold each



FLX-LG-EC-BK
 Metal End Cap
 Black finish
 sold each

Mounting Layout



Power Supplies Indoor

ADUL - SPI CONTROL

DESCRIPTION	CAT NO	APPLICATION	PRIMARY VOLTAGE	SECONDARY VOLTAGE	CIRCUIT BREAKERS	MAX LOAD	CIRCUIT CAPACITY
ADUL Series Class 2 Transformer	ADUL-60-1-5-12-SPI	Indoor or Damp	100-277V AC 5% ₀ HZ	12V DC	1	60W	5A
	ADUL-150-2-5-12-SPI				2	2x60W	2x5A
	ADUL-240-3-5-12-SPI				3	3x60W	3x5A
	ADUL-320-4-5-12-SPI				4	4x60W	4x5A

ADUL - NON DIMMING

DESCRIPTION	CAT NO	APPLICATION	PRIMARY VOLTAGE	SECONDARY VOLTAGE	CIRCUIT BREAKERS	MAX LOAD	CIRCUIT CAPACITY
ADUL Series Class 2 Transformer	ADUL-120-1-4-24-D	INDOOR/ DAMP	100-277V AC 5% ₀ Hz	24V DC	1	96W	4A
	ADUL-240-2-4-24-D				2	2x96W	2x4A
	ADUL-320-3-4-24-D				3	3x96W	3x4A

Power Supplies Outdoor

ADNM - SPI CONTROL

DESCRIPTION	CAT NO	APPLICATION	PRIMARY VOLTAGE	SECONDARY VOLTAGE	CIRCUIT BREAKERS	MAX LOAD	CIRCUIT CAPACITY
ADNM Series Class 2 Transformer	ADNM-60-1-5-12-SPI	Indoor or Damp	100-277V AC 5% ₀ HZ	12V DC	1	60W	5A
	ADNM-150-2-5-12-SPI				2	2x60W	2x5A
	ADNM-240-3-5-12-SPI				3	3x60W	3x5A
	ADNM-320-4-5-12-SPI				4	4x60W	4x5A

ADNM - NON DIMMING

DESCRIPTION	CAT NO	APPLICATION	PRIMARY VOLTAGE	SECONDARY VOLTAGE	CIRCUIT BREAKERS	MAX LOAD	CIRCUIT CAPACITY
ADNM Series Class 2 Transformer	ADNM-120-1-4-24-D	INDOOR/ DAMP	100-277V AC 5% ₀ Hz	24V DC	1	96W	4A
	ADNM-240-2-4-24-D				2	2x96W	2x4A
	ADNM-320-3-4-24-D				3	3x96W	3x4A